

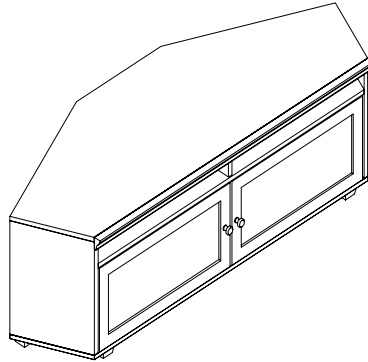

B-Cubed 3106 Media Corner - w/ Feet



Thank you for purchasing our products. Assembly of this product requires a phillips screwdriver.

We recommend two people when assembling the Corner Media.

Lay out parts on a non-abrasive surface to avoid scratching finish.

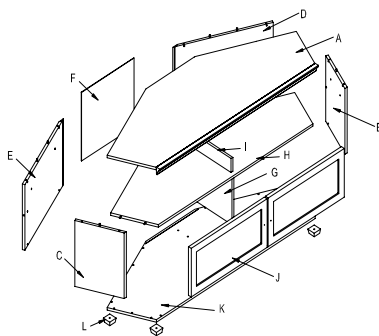

NO.	DRAWING	DESCRIPTION	QTY	NO.	DRAWING	DESCRIPTION	QTY
A		TOP	1	G		FIXED DIVIDER	1
B		RIGHT END	1	H		HORIZONTAL SHELF	1
C		LEFT END	1	I		VERTICAL DIVIDER	1
D		RIGHT BACK	1	J		DOORS	2
E		LEFT BACK	1	K		BOTTOM	1
F		CUBE BACK	1	L		FEEL	5

NO.	DRAWING	DESCRIPTION	QTY
M		MINIFIX CAM	22
N		MINIFIX CONNECTING BOLT	22
O		WIRE GUIDE	2
P		PLASTIC CAPS	22
Q		HEADLESS ROD	5
R		WOOD SCREW 4.0*14	7
S		WOOD KNOBS	2
T		KNOB SCREWS	2
U		INSERT HINGES-HINGE	4
V		HINGE SCREWS	8

STEP 1

Identify and count all parts using diagram above.

STEP 2

Identify and count all hardware.

Step 3

Position Bottom (K) w/ groove facing down on a non-abrasive surface. Screw Headless Rod (Q) into threaded inserts (5 places). Attach Feet (L) by screwing them into the opposite end of headless rod. Square the feet up to the edges. Position Bottom (K) with groove up. Thread Minifix Connection Bolts (N) into threaded inserts (10 places).

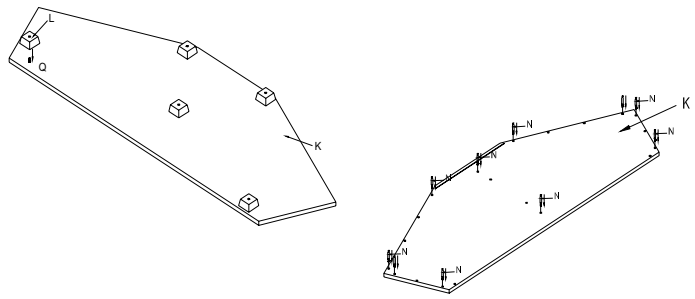

STEP 4

Position Left and Right Ends (B) & (C) and Horizontal Shelf (H) with inserts facing up on non-abrasive surface. Thread Minifix Connecting Bolts (N) into threaded inserts on both parts (4 places). Tighten bolts using phillips screw driver.

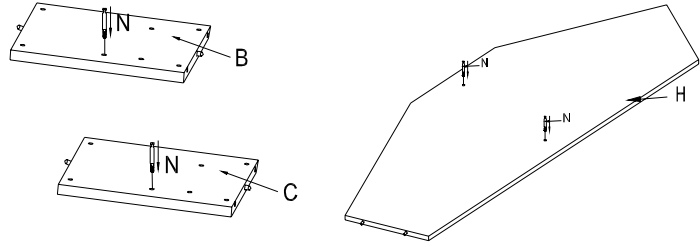

STEP 5

Position Top (A) with groove facing up on a non-abrasive surface. Thread Minifix Connecting Bolts (N) into threaded inserts (8 places). Tighten bolts using phillips screw driver.

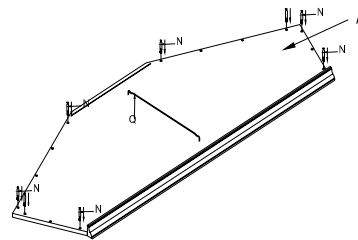

STEP 6

Attach Horizontal Shelf (H) to Left and Right Ends (B) & (C) and Left and Right Backs (D) & (E). Do this by Aligning Minifix Cam Bolts in Ends (B) & (C) to Minifix Cam holes in the edges of Horizontal Shelf (H) and Backs (D) & (E). Insert Minifix Cams into predrilled holes in Horizontal Shelf (H) and Left and Right Back (D) & (E) - (4 places). Tighten Minifix Cams using phillips head screw driver.

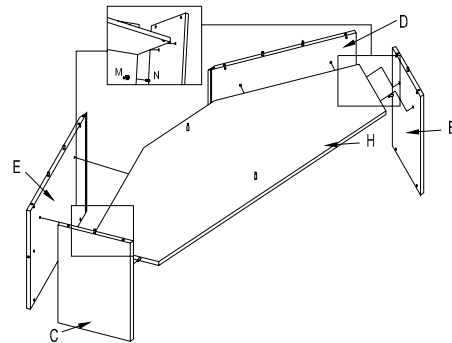

STEP 7

Attach Fixed Divider (G) by Aligning Minifix Cam Bolts in Horizontal Shelf the Minifix Cam holes in the edges of the Fixed Divider. Insert Minifix Cams (K) into pre-drilled holes in Fixed Divider. Tighten Cams using phillips head screw driver.

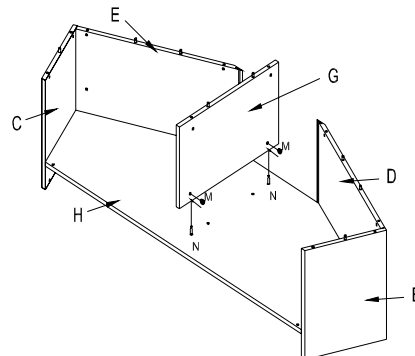

STEP 8

Attach Bottom (K) by aligning Minifix Cam Bolts (N) in bottom to Minifix Cam Holes in edges of Left and Right ends and Left and Right Backs. Insert Minifix Cams (M) into pre-drilled holes in ends and backs. Tighten Cams using phillips head screw driver.

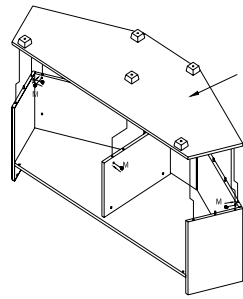

STEP 9

Slide Cube Back (F) into grooves on left and right backs and into groove in bottom. Insert Wire Guide (O) into pre-drilled holes in Horizontal Shelf. Position Vertical Divider (I) by aligning groove in edge with Wire Guide.

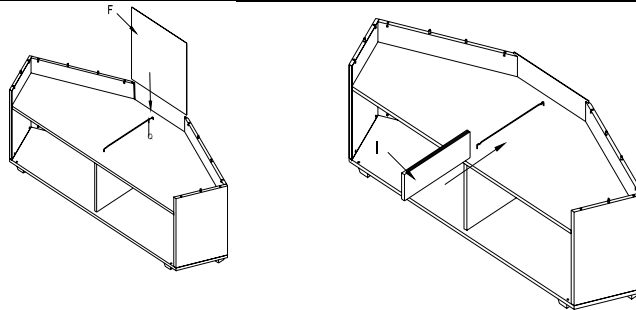

STEP 10

Attach Top (A) by aligning Minifix Cam Bolts in top to Minifix Cam holes in edges of the left and right ends & left and right Backs. Insert Minifix Cams (M) into pre-drilled holes in ends and backs. Tighten Cams using phillips head screw driver.

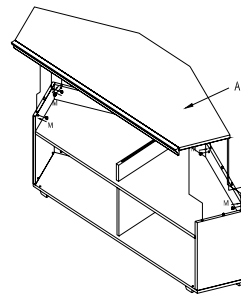

STEP 11

Attach Insert Hinge (U) to bottom of 2 Doors (J). Do this by aligning holes in hinges to pilot holes in doors. Screw in using Hinge Screw (V). Attach Knob (S) using Knob Screw (T) to Doors (J).

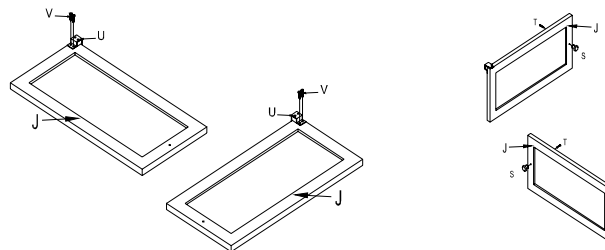

STEP 12

Install left door on Media Corner by aligning the insert hinge on bottom of door with the hinge pivot hole in bottom. Position another insert hinge (U) into hinge pivot hole on underside of horizontal shelf and while holding the hinge in place position door to align holes in insert hinge to pilot holes in top inside of door. Screw the hinge into the top inside of door Using Hinge Screw (V). Repeat process for Right Hand (opposite door).

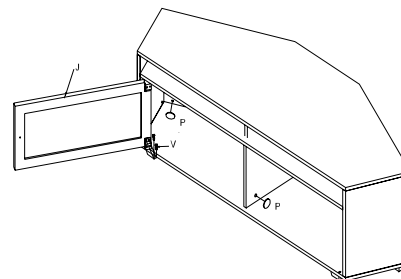

This Completes the Assembly of the Media Cabint.